

## EY-RC 311: Room controller, ecos311

### How energy efficiency is improved

Individual room control for demand-based regulation of the room temperature, lighting and sunshading to create a comfortable room climate with minimum energy consumption

### Features

- Part of the SAUTER modulo system family (BACnet MS/TP)
- BACnet MS/TP communication (EN ISO 16484-5)
- BACnet room controller (B-ASC) for fan coil unit, chilled beam, chilled ceiling, radiator heater, light, control of window blinds, variable volume flow control (VAV) etc.
- Individual adjustment of the setpoints via ecoUnit 3 room operating units (EY-RU 3\*\*)
- Optimisation of energy consumption using presence function, monitoring of window contacts, demand-controlled switching of fan speeds and time-dependent setpoint specification
- Freely configurable time programme (BACnet Schedule objects)
- Freely programmable with CASE Suite software (based on IEC 61131-3)
- Expandable with ecoLink I/O modules for lighting and control of window blinds



EY-RC311F001

### Technical data

Power supply		
Power supply		230 V, 200 V min., 253 V max., 50...60 Hz
Power consumption		Max. 14 VA
Dissipated power		5 W / 8 VA
Ambient conditions		
Operating temperature		0...45 °C
Storage and transport temperature		-20...70 °C
Air humidity		10...85% rh, no condensation
Inputs / outputs		
Relay outputs	Type	O-I relay, normally-open contacts with shared power supply
	Load	230 VAC / 30 VDC 2 A resistive load, total max. 5 A 230 VAC; 10 A resistive load
	Switching frequency	> 3 × 10 <sup>5</sup> cycles (2 A) > 2 × 10 <sup>5</sup> cycles (10 A)
Semiconductor outputs (MOS-FET)	Type	0-I, 24 VAC/DC, connected to ground
	Load	0.5 A max. peak current 1 A (< 20 ms)
Analogue outputs	Type	0...10 V / 2 mA
Universal inputs	Analogue	0...10 V
	Digital	0-I, max. 2 Hz
	Potentiometer	1...10 kΩ (for potentiometer)
	Resistor	100...2500 Ω
	Ni1000/Pt1000	-20...100 °C
Interfaces and communication		
Interface		1 × RS-485 electrically isolated, ½ load
Protocol		BACnet MS/TP
Cable		2-wire, twisted with reference, shielded
Cable length		1000 m with bus termination
SAUTER Local Communication interfaces		
Interface		1 x RS-485
Protocol		SLC
Cable		2×2-wire, twisted, shielded



Cable length	< 100 m with bus termination (with ROU) < 500 m with bus termination (without ROU)
Room operating units <sup>1)</sup>	Max. 1; EY-RU 31*, 355 or EY-RU 110, 146 (via EY-CM581)
I/O modules	Max. 2; EY-EM 51*, 52*

#### Design

Dimensions W × H × D	178 × 103 × 53 mm
Weight	674 g
Fitting	DIN rail; TH35×7.5/15 EN 50022

#### Standards, directives

Type of protection	IP00 (EN 60529) IP20 (cover with front aperture)	
Protection class	II (EN 60730-1)	
Energy class <sup>2)</sup>	I to VIII = up to 5% as per EU 811/2013, 2010/30/EU, 2009/125/EC	
Environment class	3K3 (IEC 60721)	
CE conformity according to	EMC Directive 2014/30/EU	EN 61000-6-1 EN 61000-6-3
	Low-Voltage Directive 2014/35/EU	EN 60730-1 EN 60730-2-9

#### Overview of types

Type	Description
EY-RC311F001	ecos311 - room controller B-ASC, MS/TP, 16IO, 230 V

Overview of I/O mix	
Universal inputs	5
Relay outputs	3 (2 A)
	1 (10 A)
Digital outputs	4
Analogue outputs	3

## Description of operation

The ecos311 single-room controller enables energy-optimised room control and thus ensures minimum energy consumption.

The single-room controller can be programmed with CASE Suite to fulfil the requirements of a wide range of applications in room automation as a BACnet MS/TP controller – application-specific controller (B-ASC). For example, the controller can be used for the control of fan coil units, chilled/heated ceilings, radiator heaters, underfloor heating and VAV systems. When combined with an ecoUnit room operating unit and additional ecoLink I/O modules, it can also perform further functions in the room such as control of window blinds and lighting.

## Intended use

This product is only suitable for the purpose intended by the manufacturer, as described in the “Description of operation” section.

All related product regulations must also be adhered to. Changing or converting the product is not admissible.

<sup>1)</sup> Support for ecoUnit355 (EY-RU 355) room operating unit from ecos311, firmware version 1.1

<sup>2)</sup> When the automation station is being used as a temperature controller, most temperature controller classes can be fulfilled according to EU Directive 2010/30/EU, Regulation 811/2013. For information on the exact temperature class reached, please refer to the system integrator's user program.

## Engineering notes

### Note



Only qualified electricians are permitted to fit and connect the device.  
Prevent access by laypersons.

The ecos311 controller can be fitted using a DIN rail (EN 60715) directly in the cabinet or at a suitable location in the system.

The station is powered with 230 VAC. The unit must be protected against contact. The max. power of the output (24 VAC) (terminals 27...28) is 6 VA.

The plant devices are connected using screw terminals. Parallel laying of sensor lines and high-power current-carrying cables must be avoided. When running cables for analogue signals, such as inputs/outputs (0...10 V) and inputs (Ni/Pt1000), a separate grounding must be provided for every input and output from the controller to the respective sensor or actuator. Shared ground wires lead to measurement errors that may particularly affect small measuring signals.

### DIP switches: Addressing, baud rate and voltage for room operating units

The controller requires a unique BACnet MAC address for the integration in a BACnet MS/TP network. This MS/TP master address (0...127) must be set before switching on the controller via DIP switch (table with the binary value A1-A7). In the factory setting, the controller has the address "0". It is recommended to set aside the address "0" for the BACnet MS/TP router. For optimum BACnet MS/TP communication all BACnet MS/TP MAC addresses must be assigned in continuously ascending order for each device. For the general communication in the BACnet network, a device instance number must also be stored. The device instance number and other communication parameters (Device Instance Number, Max. Master, Max. Info Frame) are set within the project using CASE Sun and CASE Engine. It is recommended to label the DIP settings on the device, on the distributor box or on the cabinet.

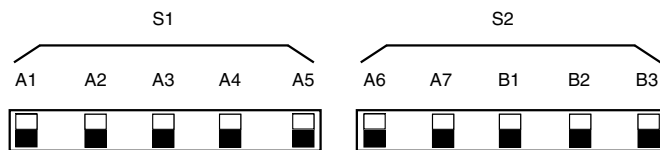

(BACnet) MAC-Address	A1	A2	A3	A4	A5	A6	A7	B1	B2	B3	Baud rate
0 (default)	0	0	0	0	0	0	0	0	0	0	115'200 (default)
1	1	0	0	0	0	0	0	1	0	0	9'600
2	0	1	0	0	0	0	0	0	1	0	19'200
3	1	1	0	0	0	0	0	1	1	0	38'400
...								0	0	1	57'600
125	1	0	1	1	1	1	1	1	0	1	76'800
126	0	1	1	1	1	1	1	0	1	1	115'200
127	1	1	1	1	1	1	1	1	1	1	reserved

DIP switches B1-B3 define the BACnet MS/TP baud rate. The state on delivery is B=0/0/0 which corresponds to the baud rate 115.2 kbit/s. B=0/0/0 can also be used for the "AUTO" baud rate in the future. For extended networks, a baud rate of 38.4 kbit/s (B=1/1/0) is recommended. Changes to the DIP switches during operation only become active after switching on again.

DIP switch S3 "5V/15V" is used for the hardware configuration of the output voltage for the room operating unit to be connected (terminal 1).

SAUTER ecoUnit31\*, 34\* room operating units and the ecoUnit580 EnOcean SLC wireless interface are supplied with +5 V.

SAUTER ecoUnit35\* room operating units and the ecosCom581 EnOcean SLC wireless interface can be supplied with +15 V.

In the factory setting, the DIP switch is set to +5 V.

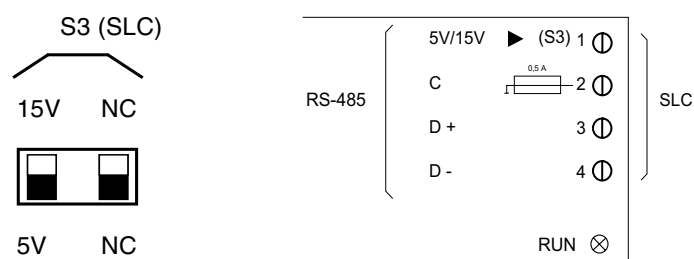

### Fitting and power supply

The controller is a compact unit suitable for wall mounting on a DIN rail (35 mm).

The following conditions must be observed:

- The device may only be connected when the system is disconnected from the electrical supply.
- The plant devices are connected via screw terminals with the appropriate torques (see fitting instructions).
- The controller must be protected against contact.
- The device must not be installed in vibrating systems, for example on transport, because the vibrations can cause micro-interruptions in the relays.
- For terminals 5...28 and 33...38, the admissible conductor cross-section is min. 0.8 mm<sup>2</sup>, max. 2.5 mm<sup>2</sup>.
- In series to terminal L, the power supply (230 VAC), a suitable external fuse (10 A slow-blow) must be installed in accordance with applicable installation regulations.
- The 2A relays (terminals 35...37) with the L/LS connection (terminal 38) and the 10A relay (terminal 34) with phase connection L (terminal 33) are mains supply circuits and must be protected accordingly.
- The semiconductor digital outputs (DO-FET) connect the loads, which can be supplied by the power supply (24 VAC, terminals 27...28, max. 6 VA), to the ground.
- The universal inputs (terminals 13...22), analogue outputs (terminals 5...10) and RS-485 (D-, D+, C) are SELV electrical circuits. SELV electrical circuits must be laid separately from the mains supply circuits (low voltage) and the functional extra low voltage (FELV).
- 0...10 V analogue outputs must not be misused as DIM outputs.
- The national standards and installation rules must be adhered to.
- Special standards such as IEC/EN 61508, IEC/EN 61511, IEC/EN 61131-1, IEC/EN 61131-2 and similar were not taken into account.
- Local standards regarding installation, application, access, access rights, accident prevention, safety, dismantling and disposal must be taken into account.
- Installation standards EN 50178, 50310, 50110, 50274, 61140 and similar ones must be adhered to.
- For more information, see fitting instructions P100016382.

### Additional information

Fitting instructions	P100016382
Declaration on materials and the environment	MD 94.310

### Network and communication

- The communication wiring must be carried out correctly, be separated from the power-carrying wiring and must adhere to the specifications of standards EN 50174-1, EN 50174-2 and EN 50174-3.
- The max. admissible bus length for the communication (BACnet MS/TP, SLC) depends on the cable type used and the correct terminating resistors. In general, a 4-wire shielded cable with twisted wire pairs must be used (minimum 0.2 mm<sup>2</sup>, recommended minimum 0.5 mm<sup>2</sup>). Observe the correct polarity of all signals. The cable shield of the entire bus line must be connected continuously, and connected to protective earth as directly as possible (max. 8 cm) at one location. This is to achieve optimum resistance to interference.
- For CAT-5 cables, as well as IYST-Y cables, a bus length of up to 500 m is possible for SLC and up to 1000 m for BACnet MS/TP. In the case of RS-485 interfaces, the bus wiring must have line

topology. Star, tree or branch topologies are not recommended. The devices do not have internal terminating resistors. Therefore, a terminating resistor of 120 Ω (0.25 W) must be connected at the start and end of the bus line, parallel to the D+/D- data lines.

- For BACnet MS/TP segments, max. 50 ecos311 (each ½ unit load) are possible. However, it is recommended to keep the segments as small as possible; for the reactivity to the BACnet visualisations, around 30 to 40 ecos311 in an MS/TP segment is practical, with the MS/TP still having sufficiently fast bus communication performance.
- For master-slave room zones with fast, synchronous switching, it is recommended to limit the number of BACnet MS/TP devices to 20 to 24 per segment.
- RS-485 repeaters are not recommended. Standard BACnet IP<>MS/TP routers with one or more ports can integrate the MS/TP segments in a BACnet/IP higher-level BACnet network. We recommend certified BACnet routers (e.g. from Contemporary Controls, KMC Controls, Loytec, MBS Software and Metz Connect).
- For more information, see fitting instructions P100015382.

## Technical specifications of the inputs and outputs

### Universal inputs (UI)

Five universal inputs are available.

The functions for the inputs and the input ranges are parameterised with CASE Engine.

<b>Type of inputs</b>	Voltage (U) Ni1000/Pt1000 Resistance (R) Potentiometer (Pot) Digital input (DI)
<b>Number of inputs</b>	5
Protection against external voltage:	±30 V/24 VAC (without destruction)
Input impedance (Ri)	≥ 80 kΩ
Resolution	10 bit
Scan rate	≤ 100 ms (analogue/digital values)
Refresh rate	≤ 100 ms (ecos311)
<b>Voltage (U)</b>	
Measuring range	0 (2)...10 V / 0 (0.2)...1 V
Resolution	≤ 0.1 V / ≤ 0.01 V
Accuracy	±0.2 V / ±0.02 V
<b>Current (I)</b>	
Measuring range	With external resistance and voltage input (U) Measuring range 0 (2)...10 V: 500 Ω = 0(4)...20 mA Measuring range 0 (0.2)...1 V: 50 Ω = 0(4)...20 mA
<b>Ni1000</b>	DIN 43760
<b>Pt1000</b>	IEC 751
Measuring range	-20...100 °C
Resolution	≤ 0.3 K
Accuracy	±1 K
Measurement current	≤ 1 mA
<b>Resistance (R)</b>	
Measuring range	100...2500 Ω
Resolution	≤ 5 Ω
Accuracy	±25 Ω
Measurement current	≤ 1 mA
<b>Potentiometer</b>	
Measuring range	0...100% (position)
Nominal resistance	1...10 kΩ
Resolution	≤ 1 % of the measuring range
Accuracy	±2 % of the measuring range
Output 10V (terminal 11/12), max. load	≤ 10 mA (i.e. ≥ 1 kΩ)
<b>Digital input</b>	

Potential-free contacts	Connected to ground I: < 1.5 k $\Omega$ O: > 7 k $\Omega$
Output current	$\leq$ 1 mA
Voltage signal	I: 0...1.5 V O: 3...11 V
Meter input	Max. 2 Hz (min. pulse duration 250 ms)

#### Voltage measurement (U)

The voltage to be measured is connected between an input terminal and a ground terminal. The signal must be potential-free. Two measuring ranges are available 0...10 V and 0...1 V.

#### Current measurement (I)

A current measurement 0(4)...20 mA is possible via an external resistor. The current to be measured is connected parallel to the resistor at one of the input terminals and a ground terminal. The accuracy of the current measurement is the result of the accuracy of the voltage input and the tolerance of the resistor. It is preferable to use a 50  $\Omega$  resistor in order to keep the effect of self-heating on the accuracy to a minimum. The current signal must be potential-free. A separate ground terminal must be used for the current measurement. Otherwise, zero-point shifts may lead to imprecise measurements in the case of other measuring signals.

#### Temperature measurement (Ni/Pt), resistance measurement (R)

The Ni/Pt1000 sensors and resistors are connected using two wires between one of the input terminals and one of the related ground terminals. For the temperature measurement it is not recommended to use an external, shared ground point. The inputs require no calibration and can be used immediately. Long sensor cables with corresponding cable resistance can be compensated in the plan. At a cable resistance of 2  $\Omega$  (cable cross-section 1.5 mm<sup>2</sup>, 85 m) of an Ni1000 sensor, the function module CH\_AI receives the scaling parameters Offset b = -0,435 and Scaling a = 1 (for operating point 21 °C). Other cable resistances can be calculated and can be compensated via the parameterisation in CASE Engine. The measuring range for the resistance measurement is limited to 2500  $\Omega$ . If line break detection is desired, a threshold of, for example, 2400  $\Omega$  can be set in the automation program (ecos311).

#### Potentiometer (Pot)

This configuration is used to record the position of the potentiometer in the range 0...100%. The nominal resistance of the potentiometer is connected between the 10 V output (terminal 11/12) and a ground terminal. The sliding contact of the potentiometer is connected to one of the input terminals. Terminals 11 and 12 are used exclusively to supply the potentiometers, as shown in the connection diagram. The output must not be connected to other devices. If multiple potentiometers are connected to terminals 11 and 12, the specified max. load must be adhered to. The ratiometric measuring method compares the sliding contact voltage at the input with the voltage at the 10 V output and determines the position of the potentiometer in the range 0...100 %. The cable resistance can restrict the measuring range (0-100%), and this can be considered in the engineering and evaluation.

#### Digital inputs (DI)

The digital input function can be used with both potential-free contacts and voltage signals. Potential-free contacts and voltage signals are connected between an input terminal and a ground terminal. Digital inputs are generally used as alarm/status inputs. Therefore, an open contact corresponds to the state 0 - INACTIVE (bit=0). A closed contact corresponds to the state 1 - ACTIVE (bit=1). This assignment, defined as normal polarity, can be inverted using CASE Engine if required.

#### Analogue outputs (AO)

Number of outputs	3
Type of outputs	0(2)...10 V
Load	$\leq$ 2 mA
Resolution	0.1 V
Accuracy	$\pm$ 0.4 V
Refresh rate	$\leq$ 100 ms (ecos311)
Settling time	1 s

The output voltage is taken from between the relevant output terminal and a ground terminal. Every output can be subjected to a load of 2 mA (the outputs do not have an active sink capability). The analogue output is short circuit-proof and grounded and is protected from external voltage. Permanent short-circuiting of multiple outputs leads to their thermal destruction. A short circuit of the AO or the reference output +10V can also cause undesired I/O states (e.g. drops in the relays) in the device.

#### Relay outputs (2A)

Number of outputs	3
Type of outputs	0-I relay, normally-open contacts (NO)
Nominal load per contact	2 A resistive load 2 A inductive load ( $\cos\phi > 0.4$ )
Start-up current	$\leq 30$ A for max. 20 ms
Total current for all contacts	$\leq 5$ A
Switching frequency	$> 3 \times 10^5$ cycles for nominal load
Refresh rate	$\leq 100$ ms (ecos311)

The relay outputs are supplied via a common feed L/LS (terminal 38). The relay contacts are intended to activate fan coil units. The relays have an increased start-up current compatibility. Peak inrush current at relay contact NO (work contact) 30 A for a maximum of 20 ms. In operating status, the total current over this terminal must not exceed 5 A. The digital outputs can be defined for single- or multi-layered functions. Real feedbacks are only possible via digital inputs.

#### Relay outputs (10A)

Number of outputs	1
Type of outputs	0-I relay, normally-open contacts (NO)
Switching voltage	250 V
Nominal load per contact	10 A resistive load 3 A inductive load ( $\cos\phi > 0.4$ )
Start-up current	$\leq 80$ A for max. 20 ms
Switching frequency	$> 2 \times 10^5$ cycles for nominal load
Refresh rate	$\leq 100$ ms (ecos311)

The relay output has a separate feed L (terminal 33). The relay contact is for controlling units with higher power such as a pump or a heating coil. The relay has an increased start-up current compatibility. Peak inrush current at relay contact NO (work contact) 80 A for a maximum of 20 ms. Real feedback is only possible via a digital input.







#### Digital outputs (FET semiconductors)

Number of outputs	4
Type of outputs	MOS-FET semiconductor, connected to ground
Load on outputs	24 VAC/DC, 0.5 A (resistive load)
Start-up current	$\leq 1$ A for max. 20 ms
Refresh rate	$\leq 100$ ms (ecos311)

The actuator to be switched (e.g. thermal actuator) is connected directly to the semiconductor switch terminal. For thermal actuators, the power supply can be taken from the terminal (24 VAC). Real feedbacks are only possible via digital inputs. Actuators with high start-up currents (e.g. motor protection) must not be used with the power supply (24 VAC); an overload ( $> 0.25$  A) of the output (24 V) is prevented via a thermal polyfuse (PTC); in this case an external transformer (24 V) must be used, whereby the switch rating of the MOS-FET must not exceed 0.5 A.

### Run/fault LED indicator

The operating status of the device is indicated by the Run/Fault LED.

Status <sup>3)</sup>	Indicator/dis- play	Description
LED off		Device off (without power supply)
Continuous green		Normal mode
Flashing green		Identification via CASE Sun
Continuous orange		In startup mode
Flashing orange		The internal backup battery must be replaced
Continuous red		No CASE Engine plan in ecos (BACnet: "Download required")
Flashing red		Program download or configuration active or firmware update

### BACnet and DDC function with CASE Suite

The ecos311 room controller is a BACnet MS/TP device as per BACnet device profile B-ASC (BACnet Application Specific Controller) with the additional support of BACnet Schedule and Calendar objects. The controller is programmable with function blocks with CASE Suite. The program is downloaded to the controller via a BACnet router with CASE Engine. The switch-on phase of the controller is around 10 seconds. The controller has a plan cycle time of 100 ms. Relevant process data (e.g. setpoint as Present Value of an AV object) can be parameterised so that it is saved persistently (serial battery-supported SRAM). A firmware update can be carried out with CASE Sun via BACnet router and uses standard BACnet methods.

The following function limits apply:

Function, BACnet object	Quantity
BACnet Value objects (analogue, binary, multi-state)	50
BACnet Loop objects	6
BACnet Schedule objects	4
BACnet Calendar objects	3
BACnet Client (DS-RP-A/DS-COV-A with EXT_VAL function block)	16
Optimisation modules (OPT_H + OPT_C)	4
Group communication modules (GRPCOM_B)	32
Group communication modules (GRPCOM_R + GRPCOM_U)	12
Room operating unit module (ROOM_UNIT)	1
Number of ecoLink modules	2
Number of COV logins	64
Max. number of master-slave devices in a group	8 (1 master, up to 7 slaves)
Number of function modules (without BACnet objects), total	200

Further information on BACnet and DDC functionality is available in the BACnet PICS (Protocol Implementation Conformance Statement) and the online help for CASE Suite.

### Integration of the inputs and outputs, the ecoLink modules and the room operating unit with CASE Suite

The engineering of the inputs and outputs of the ecos311 and the ecoLink modules is performed using CASE Suite. When an ecos311 room controller is selected in the BACnet MS/TP network plan, it can be created for one, two or up to eight master-slave rooms in an AS group. The types and addresses of the required ecoLink modules (1,2) and room operating unit (1) are then defined in the Definition module within CASE Engine. After this, all the inputs/outputs of the ecos311, the ecoLink modules and the room operating unit can be used in CASE Engine as a channel (CH\_Ax, CH\_Bx) and as a ROOM\_UNIT and be mapped to BACnet data points (value objects).

<sup>3)</sup> LED flashing: 500 ms on, 500 ms off



### Time, battery

The controller has an internal clock with a date (Real-Time Clock). If the power supply is interrupted, the time (RTC) is preserved by the button-cell battery (CR2032). The accuracy of the time is around 50 ppm (max. 30 minutes per year). It is possible to use BACnet time synchronisation services such as DM-UTC and DM-TS in order to synchronise all controllers to the same time. When the LED flashes orange, this means that the battery must be replaced. See also fitting instructions. After the battery is replaced, the time and date on the controller must be reset using CASE or BACnet.

### 24 VAC output - notes on the internal transformer

The internal transformer with an output voltage of 24 VAC is designed for a load of max. 6 VA / 0.25 A. Terminals 27, 28 supply 24 VAC (max. 0.25 A) for direct control of an AXT thermal actuator for unit valves. The semiconductor switch (MOS-FET) switches the load to ground. For AXT, the DO-FET can be activated quasi-continuously with a PWM algorithm. The technical documentation of the respective actuators must be considered. The open-circuit voltage of the output (24 VAC) depends on the primary-side 230 VAC power supply and is around 28.5 VAC. With a power supply of 200 VAC (230 VAC  $-13\%$ ) at around 25 VAC and at  $+10\%$  around 31 VAC. When there is a load on the output, the voltage decreases quasi-linearly (around 1.5 V per 100 mA). If devices are supplied by the output (24 VAC) (terminals 27, 28), these tolerances must be considered. If required, it must be ensured that the power supply is not over 230 VAC so that the devices can be operated within their supply tolerances ( $\pm 15\%$  /  $\pm 20\%$ ) (see diagram).

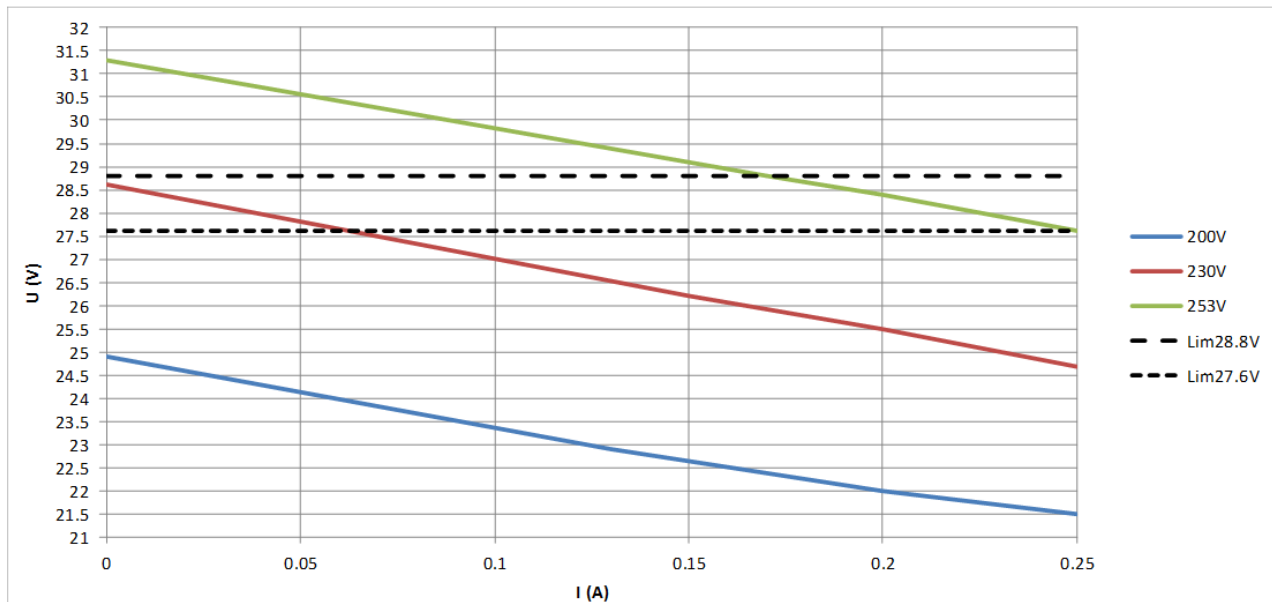

#### Note



SAUTER motorised actuators for unit valves (AXM) have a supply tolerance of  $\pm 15\%$  at 24 VAC. AXM must not be connected to the 24 VAC output of the ecos311. The actuators must be powered by an external transformer that meets the AXM supply tolerances.

### Parallel operation of multiple thermal actuators

Using an external transformer:

If the internal transformer (6 VA) is not sufficient to supply the actuators, an external transformer (e.g. 0450573001, 42 VA) can be used to connect multiple actuators with the MOS-FET semiconductor outputs (each max. 0.5 A). The external transformer must have the secondary ground connected to terminal 22, and universal inputs should use different GND terminals (e.g. terminal 20).

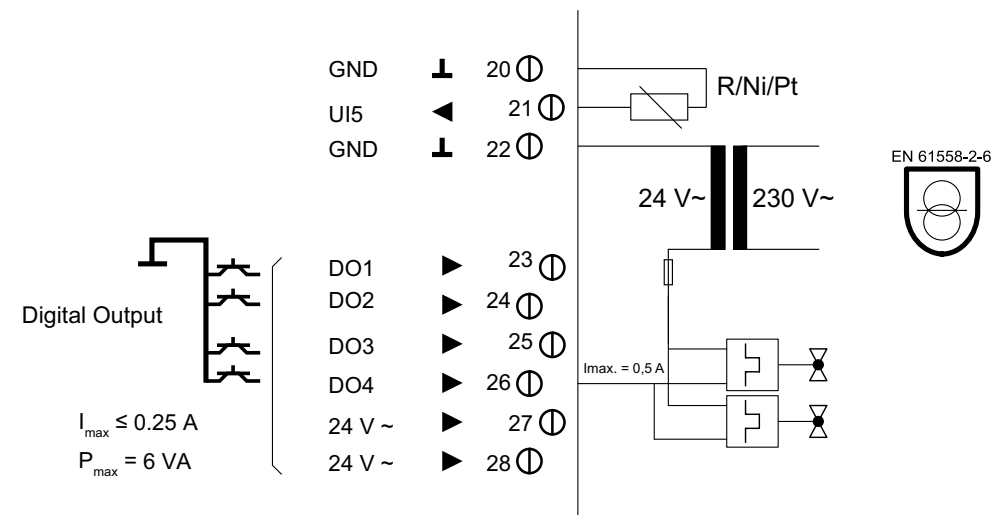

Using external semiconductor relays:

Multiple actuators can also be activated with external semiconductor relays (SSR). The number of actuators is limited by the output of the semiconductor relays.

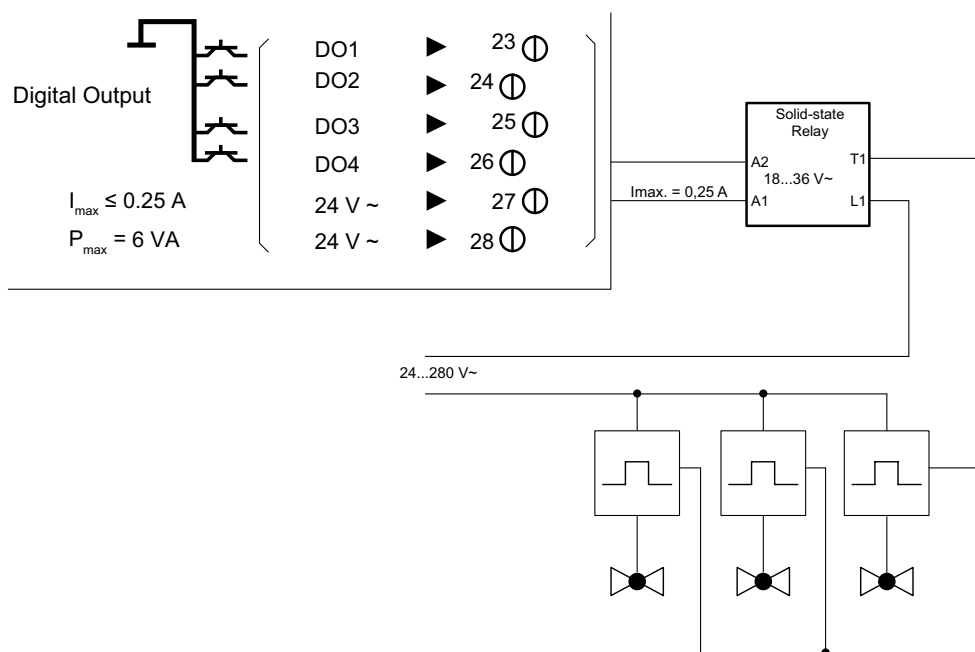

Using continuous actuators for unit valves with AXS positioners:

An analogue output (0...10 V) of the ecos311 can activate up to 15 continuous AXS units. The internal transformer with 6 VA is not suitable for supplying an AXS. The AXS must be supplied externally.

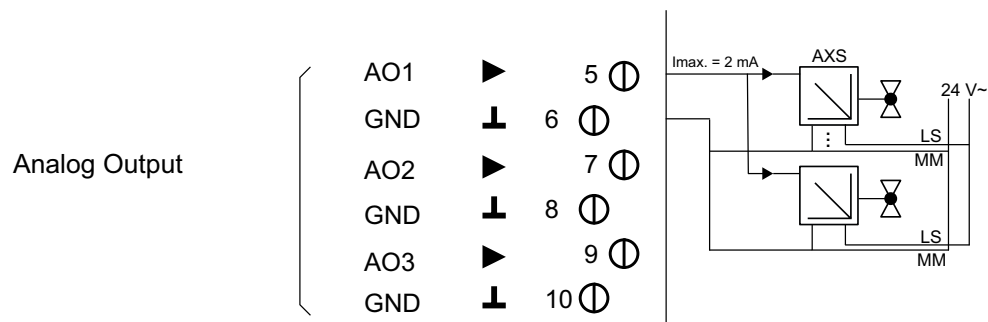

**Application for “fan coil unit system – 4-pipe”**

An example application can be set up with the following devices:

Type	Number	Description
EY-RC311F001	1	BACnet MS/TP room controller, 3 (or 4) relays, for fan coil unit (with reheater)
EY-RU 355	1	ecoUnit355 operating unit, LCD, NTC sensor, dXs setpoint adjuster, occupancy, fan
AXT***	2	Thermal actuator for unit valves (for heating and cooling sequence)
VCL025F200	2	2-way regulating valve (linear)

**Disposal**

When disposing of the product, observe the currently applicable local laws.

More information on materials can be found in the Declaration on materials and the environment for this product.

### Connection diagram

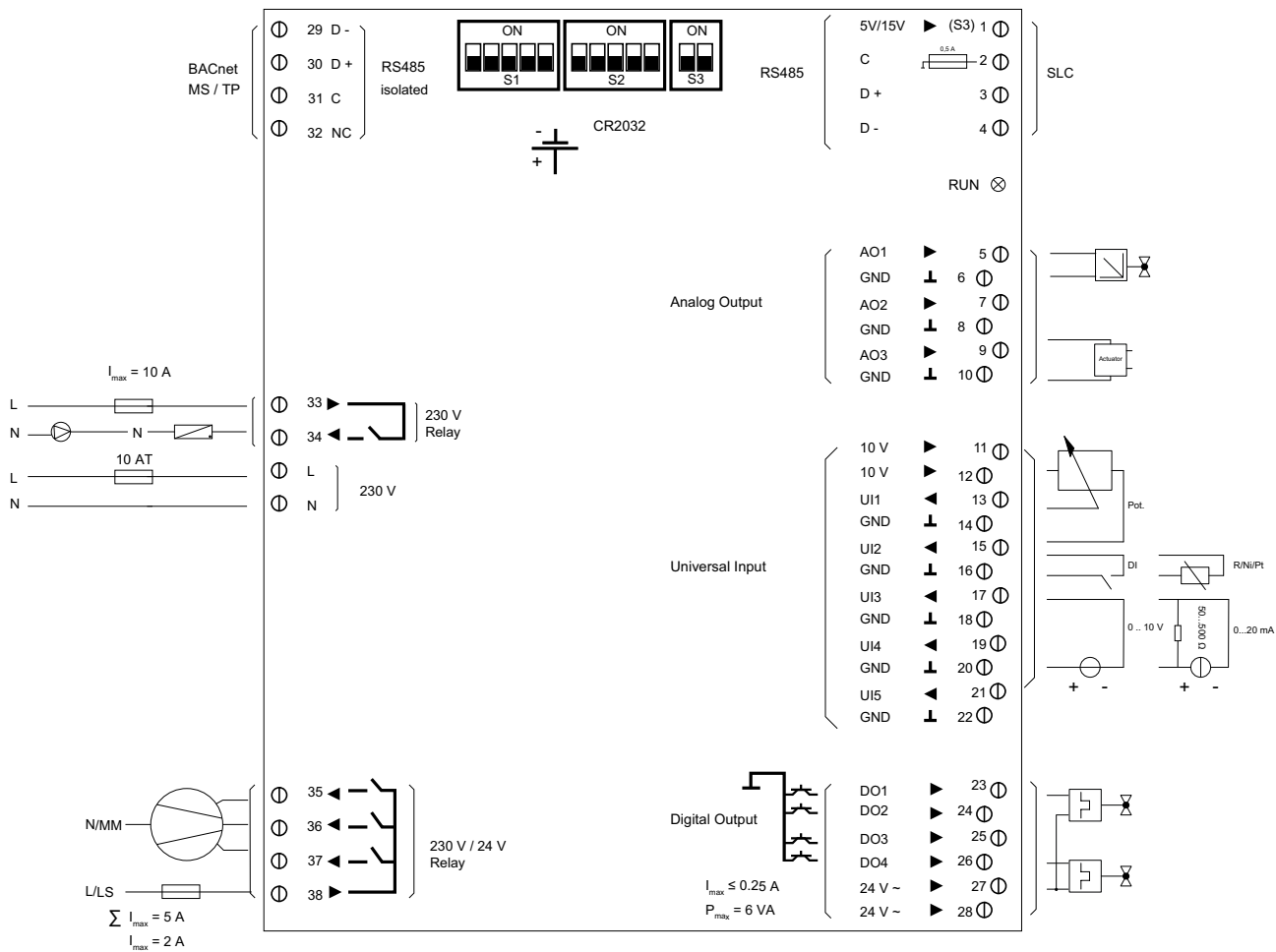

### Network

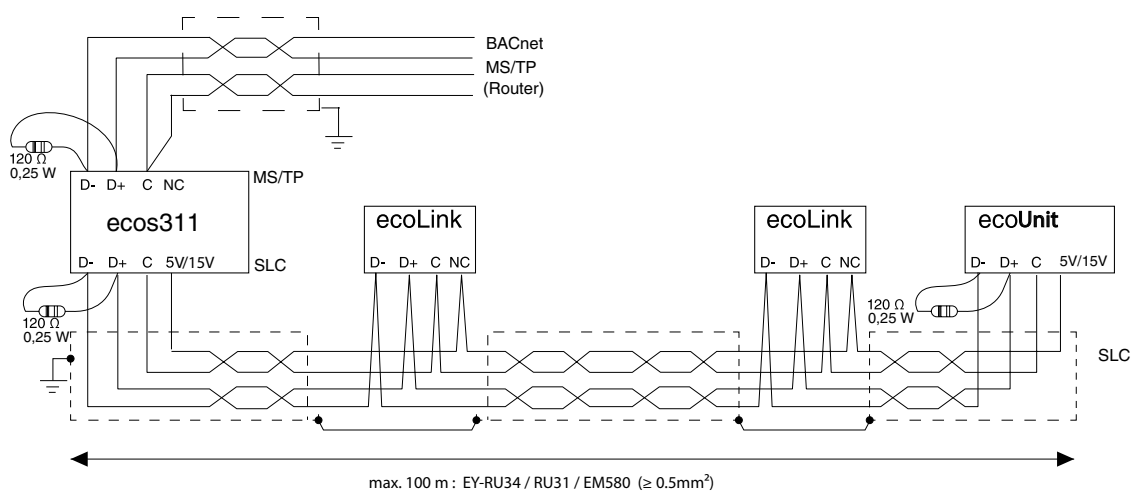

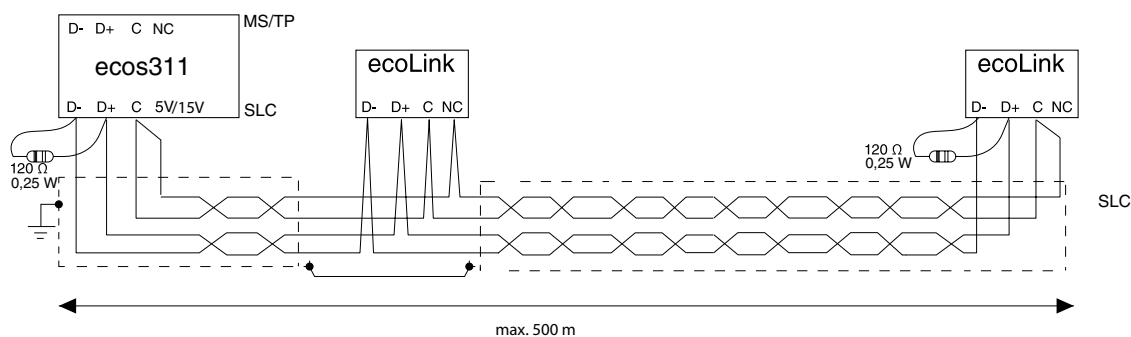

Example applications

Fan coil temperature controller with 4-pipe system

Fan coil temperature controller with 4-pipe system  
Heating via radiator

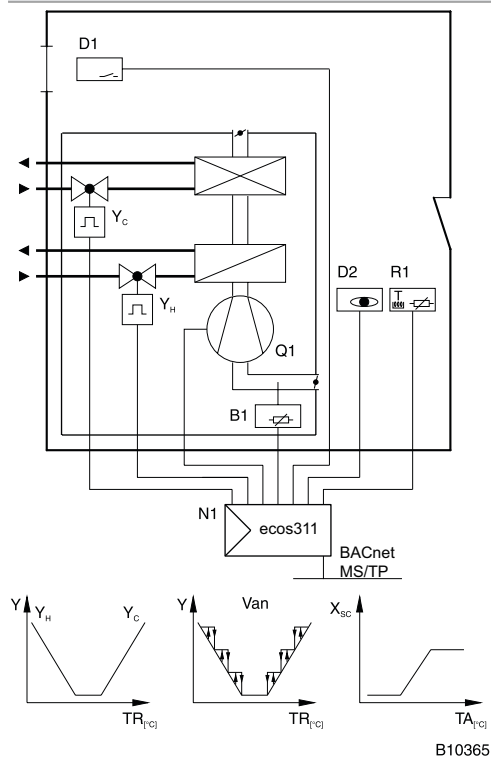

B10365

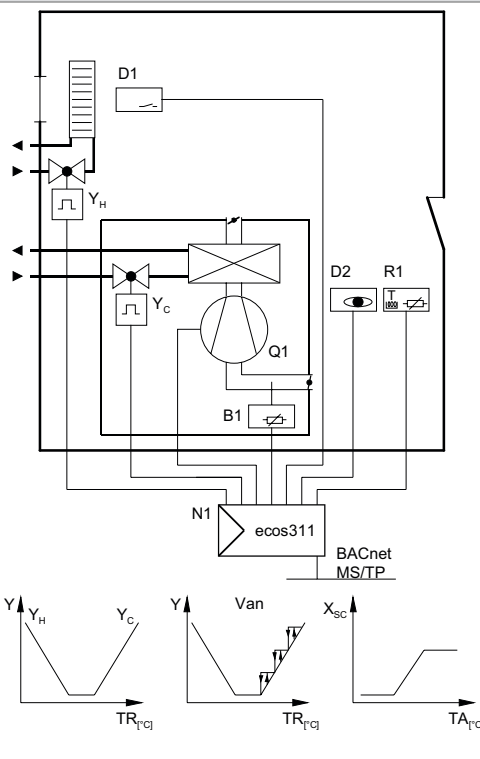

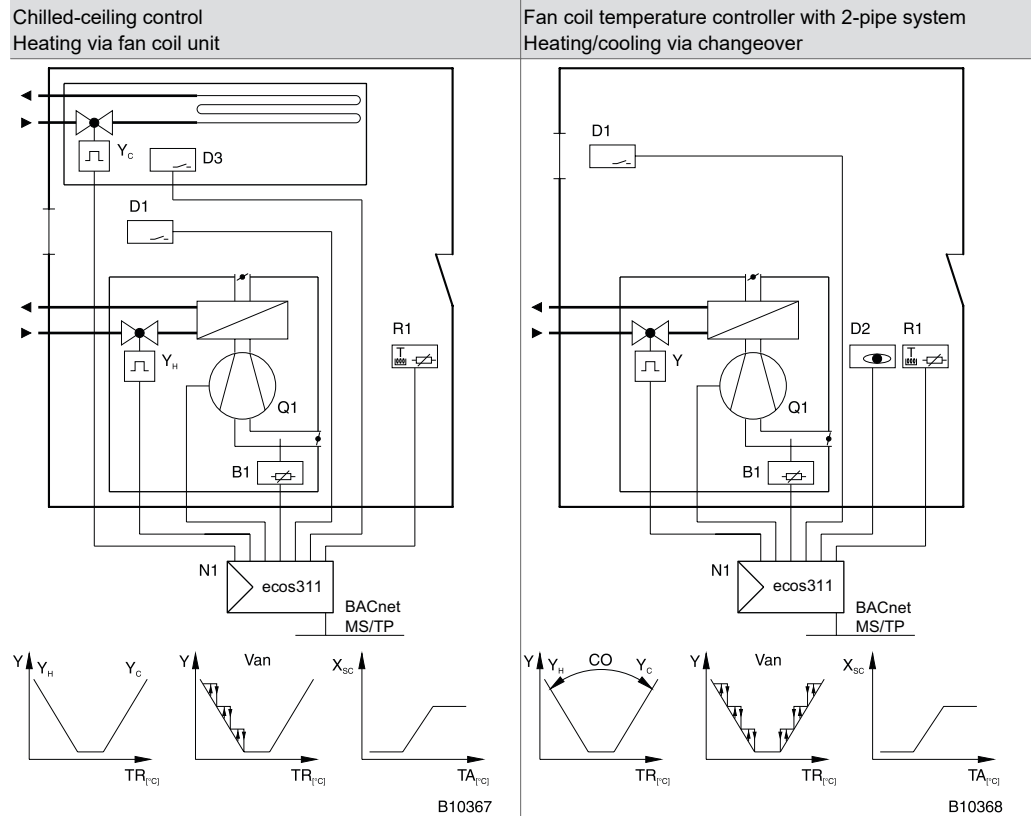

**Key**

- |    |                                     |    |                     |                |                       |
|----|-------------------------------------|----|---------------------|----------------|-----------------------|
| B1 | Temperature sensor for duct fitting | N1 | Controller          | Y              | Heating/cooling valve |
| D1 | Window contact                      | Q1 | Fan                 | Y <sub>C</sub> | Cooling valve         |
| D2 | Presence detector                   | R1 | Room operating unit | Y <sub>H</sub> | Heating valve         |
| D3 | Dew point monitor                   |    |                     |                |                       |

**Dimension drawing**

